

- _versatile_open floor plan_mixed-tenure_mix-n-match 'building blocks'
- _functional_3bd | 2.5 ba_useable private outdoor space_privacy 'green' screens
- _sustainable_holistic approach_i.e. green roof | mixed-income | inherent sense of community
- _interior|exterior_access to green space_floor-to-ceiling glass / light
- _affordable_pre-fab 'building blocks'_home ownership_potential rental income_shared maintenance
- _responsive_interactive + intertwined with community

- _residence "a" (x2):
 - 1600sf
 - 400sf green roof
- _residence "b" (x2):
 - 1600sf
 - 335sf accessory unit
 - 400sf green roof
- _6400sf primary residence (4 units)
 - 670sf accessory (2 units)
 - 1600sf green roof
- _55% lot coverage (45 % green space)
- _maximum height _35'-0"

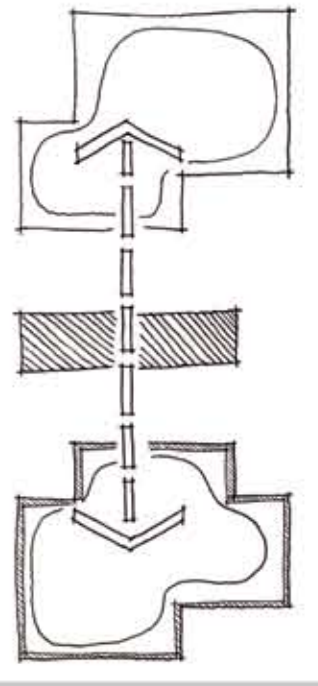
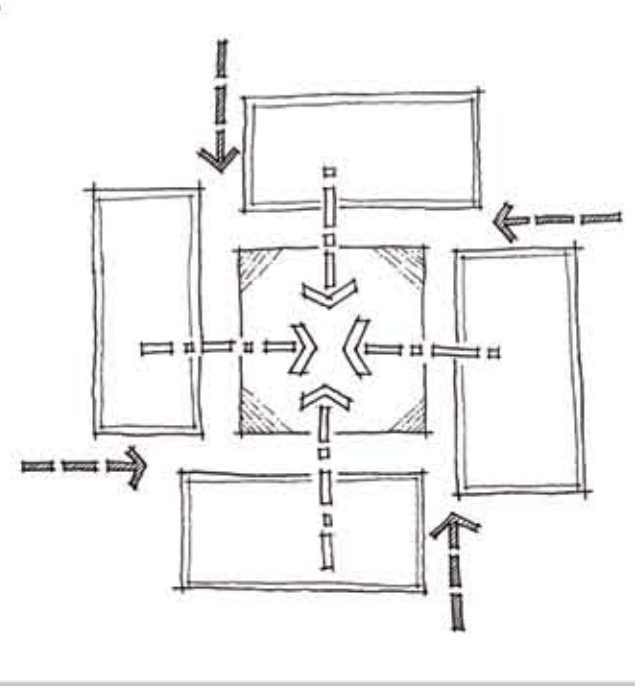

_1st floor plan | ownership

_west elevation



_north elevation



_east elevation



_south elevation



_not to scale